

CROSS SECTION A-A

CROSS SECTION B-B

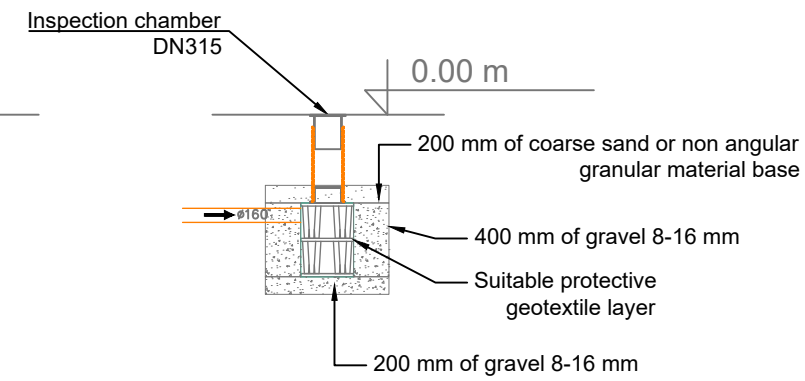
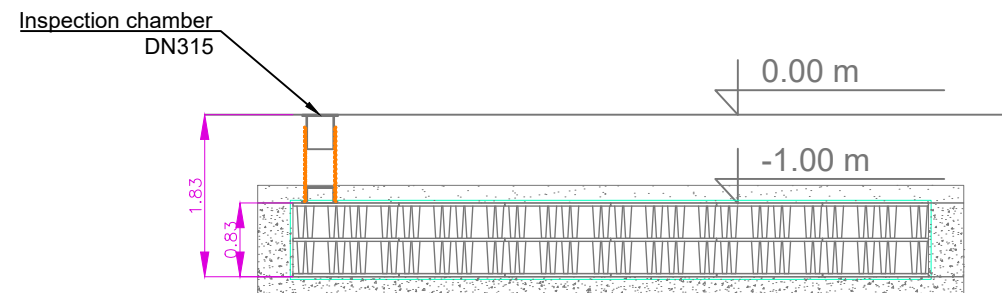

REMARKS!

1. The use of pre-treatment devices is recommended before the drainage tank (depending on the requirements - sand trap or oil separator)
2. Possibility to use the inlet in the diameter range of  $\varnothing 160$ ,  $\varnothing 200$  and  $\varnothing 315$
3. Single AquaCell NG unit has dimensions of 1.2 x 0.6 x 0.4 m (L x B x H)
4. The bottom height of 0.025m should be added to the total height of the AquaCell NG tank.

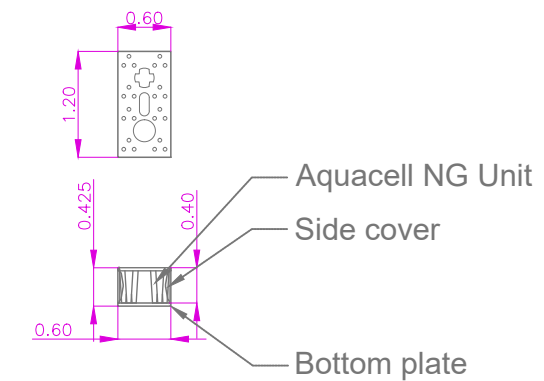

Project Name : INT-2022-011		
Project Address: BUDAPEST_III.		
Drawing name: 2022-011	Date: 17.01.2022.	
Drawn by: DGY	Iteration: 1	